



MX6 | **MX8™**

Important Information

Notice for Vinyl Liner Pools: Before installing your pool cleaner, examine the interior of your pool carefully. If the vinyl liner is brittle or has stones, wrinkles, roots or metal corrosion in contact with the underside of the liner, or has damage to the base material or supporting walls, do not install the cleaner before having a qualified professional perform the necessary repairs or liner replacement. **Zodiac Group Australia Pty Ltd (Zodiac) will not be responsible for liner damage caused by a cleaner which is in disrepair, pattern removal from a vinyl liner, or a cleaner used in a pool having an aged or deteriorated liner.** Please see Limited Warranty.

- Clean the skimmer basket, pump basket and pool filter before installing the cleaner and on a regular basis thereafter.
- Always disconnect the cleaner from the pool wall or skimmer before cleaning or backwashing the pool filter. After cleaning or backwashing, let the filtration system run for at least five (5) minutes before re-connecting the cleaner.
- Remove the cleaner from the pool before chemical or shock treatments. Wait a minimum of four (4) hours after super chlorination before re-installing the cleaner.



Read owner's manual completely before operating the cleaner.



Remove cleaner before entering the pool.



Do not operate outside of the pool.



Do not let children play with cleaner.

For customer service or support:

Zodiac Group Australia

219 Woodpark Road

Smithfield, NSW 2164

1800 688 552

Congratulations on the purchase of your new Zodiac MX6/MX8 automatic pool cleaner. Your Zodiac MX6/MX8 is designed and manufactured for easy installation, and years of carefree operation. Before installing the cleaner, please take a few moments to become familiar with its components and to review the items listed under **Important Information**.

Like most mechanical devices, the Zodiac MX6/MX8 requires periodic adjustments, routine maintenance, and the replacement of certain hardworking parts. Be sure to have the Zodiac MX6/MX8 checked occasionally by your local Zodiac dealer or service center.

Always insist on genuine Zodiac® replacement parts. Non-Zodiac parts are not made to our specifications. They may have an adverse effect on the operation of your Zodiac MX6/MX8 or may even damage it.

Zodiac MX6/MX8 Complete Cleaner

1. MX6/MX8 Cleaner Body (1)
2. AD Flow Valve & Connector (1)
3. Universal Weir Cuff (1)
4. Flow Regulator Valve (1)
5. Twist-Lock Hose Section MX8 (11) MX6 (9)
6. Leader Hose with Float (1)
7. 90 Degree Elbow (1)
8. Yellow Wheel Chip

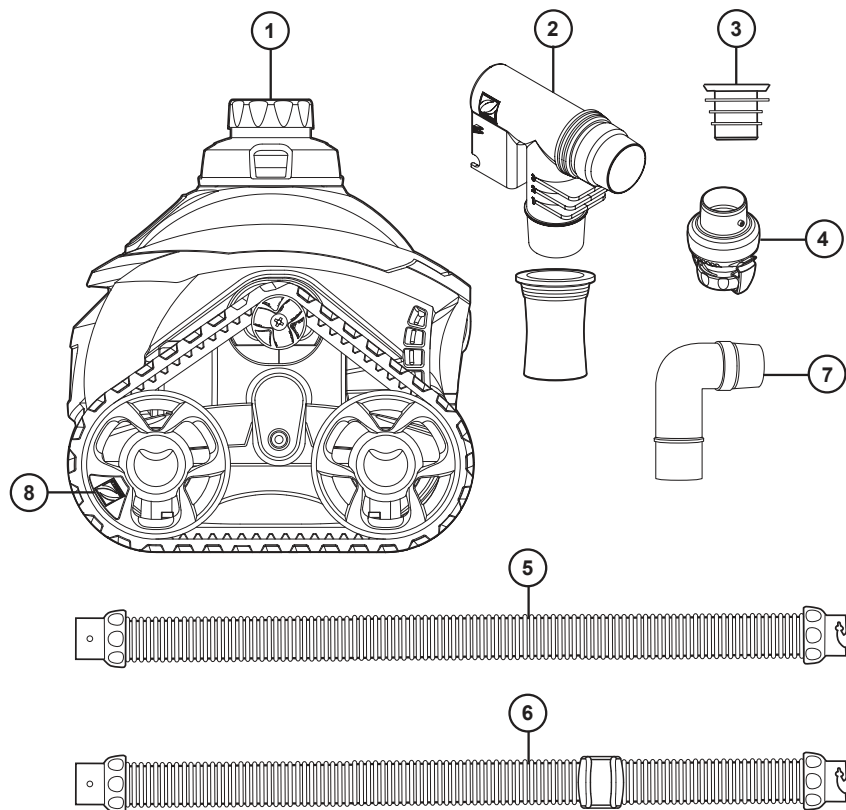

Installation

1. Before You Start

For best Zodiac pool cleaner performance, you will need to follow the following steps of the installation.

- 1.1 Following manufacturer's instructions, clean the filter and empty the skimmer and the pump strainer basket.
- 1.2 If your main drain is connected to the skimmer box, block off access.
- 1.3 Manually vacuum the pool.
- 1.4 Ensure circulation system is operating at maximum water flow, or you will need to re-adjust when it comes to clean the filter baskets.
- 1.5 Adjust water flow, from all return inlets: -
 - a) Downward and toward each other OR
 - b) Downward and toward the centre of the pool.

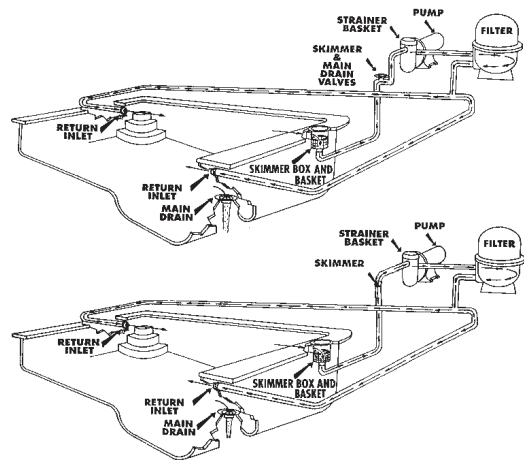

If return inlet directional fittings can't be directed far enough down to prevent water flow affecting the natural movement of the Zodiac hose, you will need to install Zodiac return line diverters. These are available from your local Zodiac dealer.

2. AD Flow Valve

The AD Flow valve works by regulating the flow through the pool cleaner to the pump. As the filter collects debris, the valve will automatically maintain the correct flow.

The installation of the AD Flow valve will depend upon the type of skimmer box and Vac plate you have. It is either installed straight in from the top of the Vac plate or from the bottom of the Vac plate.

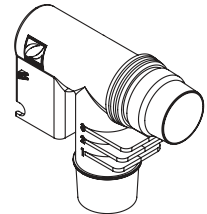

See the 4 different cases below.

1st case: with Waterco Skimmer Box/Vac Plate

Screw in the AD Flow valve connector into the top of the Vac plate



2nd case: with Poolrite Skimmer Box/Vac Plate

Screw in the AD Flow valve connector into the bottom of the Vac plate.



3rd case: with Speed Regulator/Skimtrol Vac Plate

Simply connect the 90 Degree Elbow into the top of the Vac Plate.

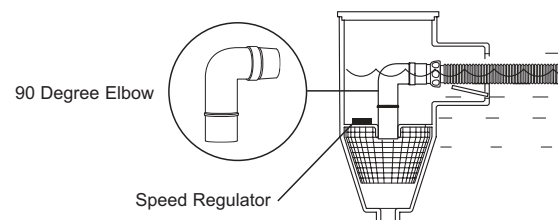

4th case: with any other type of Skimmer Box and Vac plate

Simply insert the AD Flow valve directly into the universal weir cuff which will then fit into the top of the Vac plate.

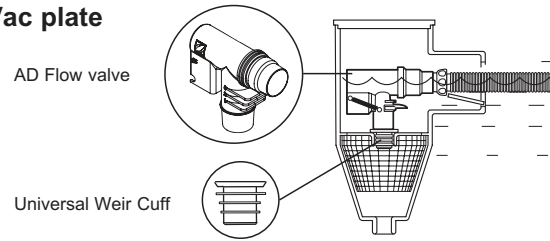

Note:

The AD Flow valve has three settings: High (3), Medium (2) and Low (1). To deliver the maximum pool cleaning efficiency, the AD Flow valve comes preset at a factory setting of 2. You will need to adjust the AD Flow valve when and if a problem occurs.

3. Assemble the hose sections



WARNING

To avoid any serious injury, **turn off the pool pump** before proceeding to this step.

Start to connect one of the standard hose to the skimmer box Vac plate. Then continue adding lengths of standard hose sections until you reach the furthest point of the pool, opposite to the skimmer box. **THEN** add the leader hose section.

See below examples.

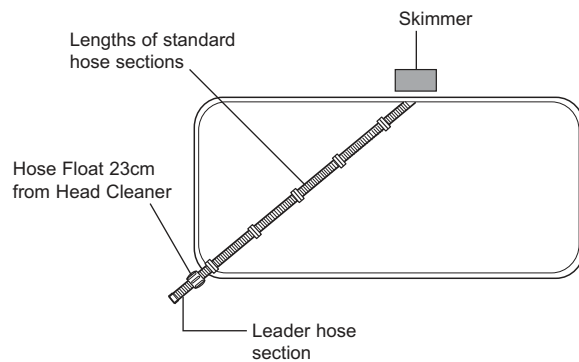
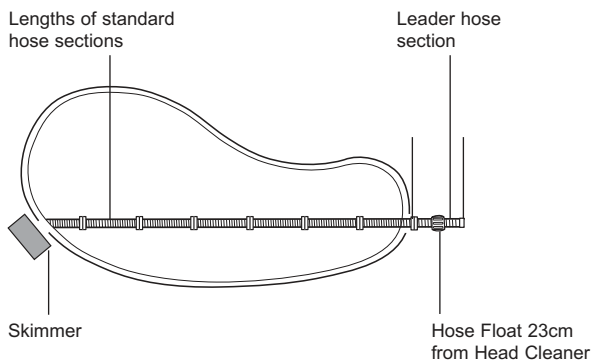

Installation

4. Connecting Cleaner head to Flow Regulator Valve

- 4.1 Remove orange sticker off leader hose
- 4.2 Attach the Flow Regulator Valve to the leader hose and connect MX6/MX8 cleaner head to the Flow Regulator Valve.

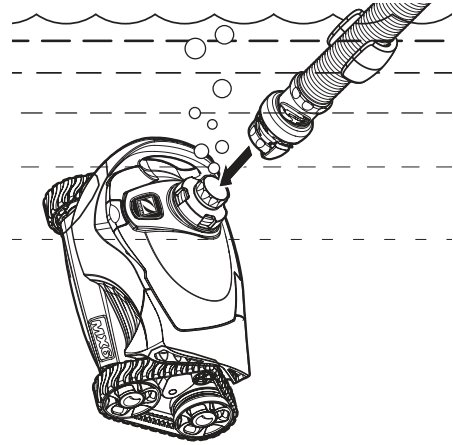
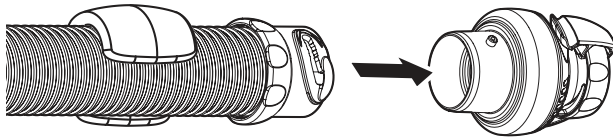

5. Re-Connecting to skimmer box

- 5.1 Temporarily disconnect hose from skimmer, turn on pool filter pump
- 5.2 Flood the hose with water, turn off pool filter pump, reconnect hose to skimmer box, then turn pool filter pump back on.

6. Check Cleaner Flow

- 6.1 Watch the yellow wheel marker, use a stopwatch to time ten (10) wheel rotations

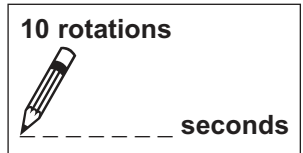

MX6/MX8:
Watch until the wheels change direction, then begin timing.
If wheels reverse while timing, you need to begin again.

IF	Time is ...	Result ...	Adjust Flow ...
	26-50	Poor Performance	Increase Flow +
	20-25		
	10-19	Possible Damage	Decrease Flow -

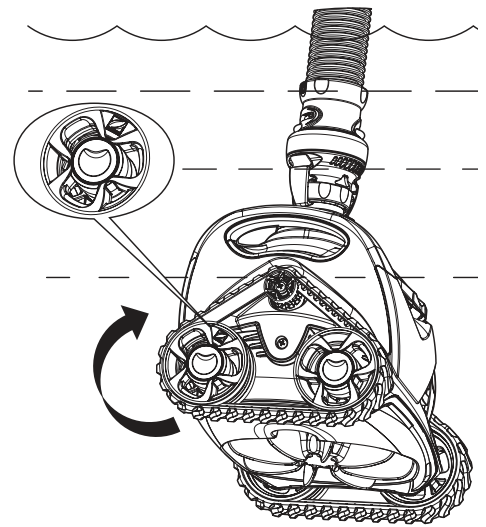

7. Adjust Flow if Necessary, using the AD Flow Valve

- 7.1 The AD Flow Valve has three settings: (1) Low, (2) Medium, and (3) High. The valve comes with a factory setting of (2).

- +** Adjust the AD Flow Valve to setting (3) to increase flow.
- Adjust the AD Flow Valve to setting (1) decrease flow.

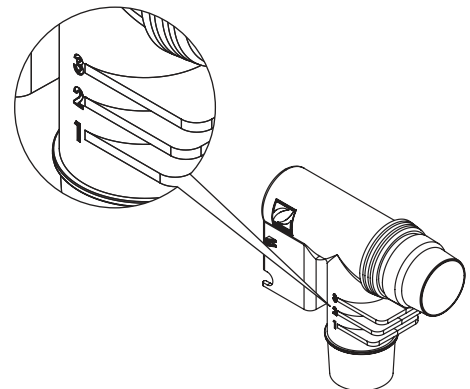

Care and Maintenance

The Zodiac MX6/MX8 cleaner cycles on/off with the pool filtration pump, vacuuming and cleaning all surfaces randomly throughout the pool. The climbing ability of the cleaner is dependent on the pool's shape and available water flow. If Zodiac MX6/MX8 is not climbing your walls, ensure the flow is correct by counting wheel speed. Also, ensure the pools surface is not covered in algae as this slippery surface will affect the cleaner's traction.

During each coverage pattern cycle, the MX8 cleaner travels both forward and backwards, and pivots to the right and left, where the MX6 cleaner only moves forward and pivots to the left. The power scrubbers underneath the cleaner create down force for climbing and stability as well as directing debris into the cleaner mouth.

Removing the cleaner out of your pool

It is most important to disconnect the head of the cleaner from the leader hose section when you take the Zodiac cleaner out of the pool.

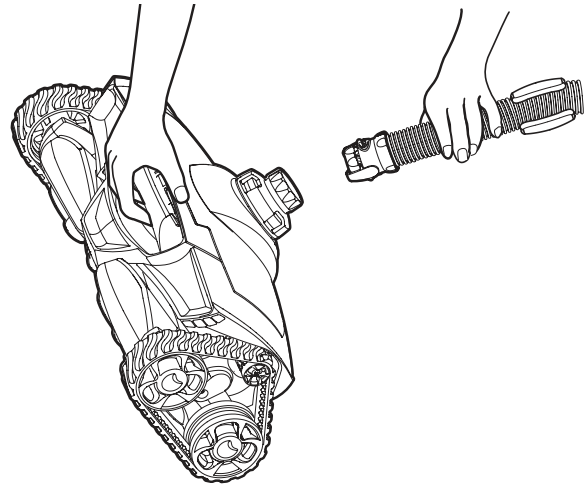

Backwashing the Pool Filter

Always disconnect the Zodiac MX6/MX8 from the pool wall before cleaning or backwashing the pool filter. After cleaning or backwashing, let the filtration system run for at least three (3) minutes to flush out the suction lines before re-connecting the cleaner.

Adding Chemicals to the Pool

Remove the cleaner from the pool for at least four (4) hours when adding chemicals.

Remove Debris from Engine

- 1) Push the latch release button on the top of the cleaner.
- 2) Rotate the top lid assembly back until it clicks into an upward position.
- 3) Look into engine and remove debris that is present.
- 4) If needed, slowly push engine paddles forward and/or backwards to move stuck debris to an accessible position then remove it. When moving the engine paddles, make sure the cleaner tracks are allowed to move freely as they will turn as the engine paddles rotate.
- 5) Close engine top and ensure the latch clicks in place.

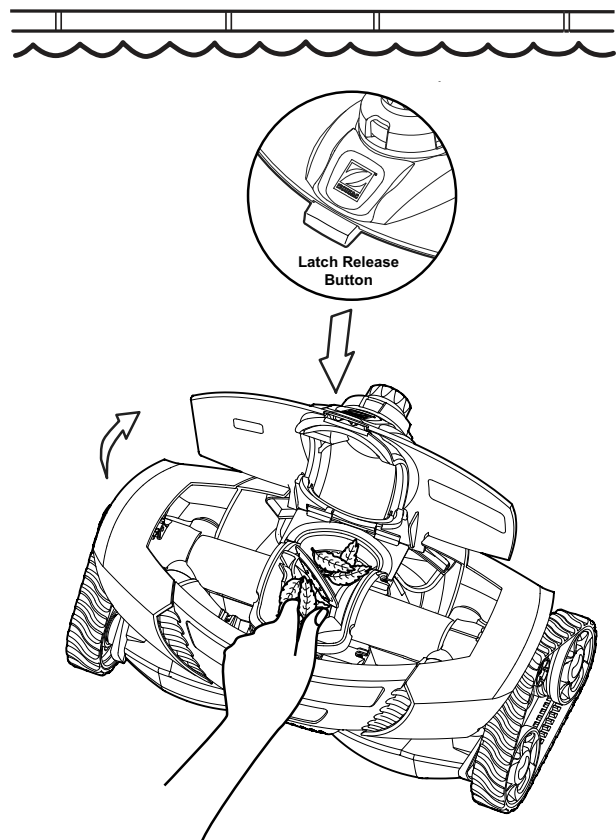

Care and Maintenance

Removing Inlet Throat Adaptor (MX8 only)

If you are experiencing high levels of larger debris that clog the throat of the cleaner simply remove the inlet throat adaptor to enhance the size of the Zodiac MX8's throat inlet, thus allowing larger debris to be picked up by the cleaner.

- 1) Grasp adaptor as shown, inserting finger into adaptor hole.
- 2) Remove by lifting up rear edge first.
- 3) To re-install simply click the front edge first then push rear into place.

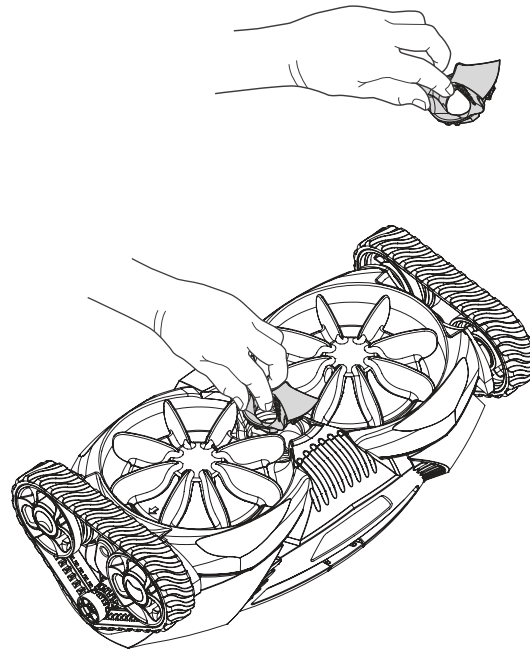

Figure 1: Removal of inlet throat adaptor

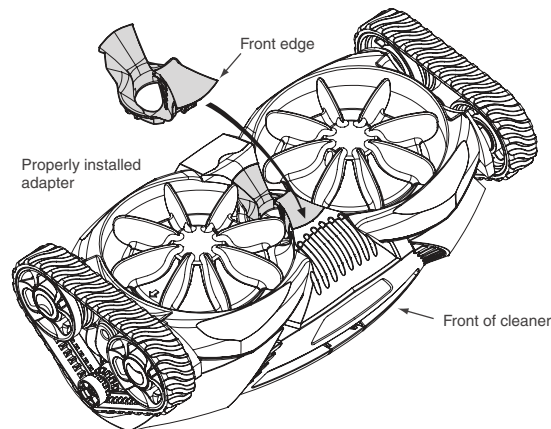

Figure 2: Installation of inlet throat adaptor

Troubleshooting

If you experience a problem with your Zodiac MX6/MX8, please follow the troubleshooting steps below to restore performance. If further assistance is required, contact Zodiac® Technical Support Department at 1800 688 552. Please have your serial number and date of purchase available when you call.

Problem	Solution
Cleaner does not move or moves slowly (+25 seconds for 10 wheel revolutions)	<ul style="list-style-type: none">• Confirm that the main drain is closed.• Check for debris jammed in engine. Backwash filter and empty pump basket.• Remove yellow inlet adaptor (MX8 only) located at the bottom of the pool cleaner. Refer to Care & Maintenance, 'Removing inlet throat adaptor' on page 8.• Check for air in system. If water level in pump basket drops or you see excessive air bubbles in the pump basket or coming from the return lines, there is air in the system. Tighten all fittings at pump.
Cleaner patterns, does not cover entire pool.	<ul style="list-style-type: none">• Count Wheel Revolutions, flow may need to be adjusted via AD Valve/Skimtrol plate.• Ensure return fittings are directed down. Add a return diverter if necessary.• Make sure hose is not kinked or coiled. Lay in sun to straighten if necessary.• Verify correct hose float positioning on the leader hose.• Observe the MX8 cleaner for more than five (5) minutes and ensure that each drive track is periodically reversing, the MX6 will only go forwards. If it is not, contact you dealer or service center for help.• Confirm proper hose length.
Cleaner gets stuck at steps.	<ul style="list-style-type: none">• Observe the MX8 cleaner for more than five (5) minutes and ensure that each drive track is periodically reversing, the MX6 will only go forwards. If it is not, contact you dealer or service center for help.• Ensure the swivel on top of the cleaner rotates freely.• Count Wheel Revolutions, flow may need to be adjusted via AD Valve/Skimtrol plate.• Confirm proper hose length. Shorten if necessary.
Cleaner won't climb walls.	<ul style="list-style-type: none">• Count Wheel Revolutions, flow may need to be adjusted via AD Valve/Skimtrol plate.• Verify correct hose float positioning on the leader hose.
Cleaner climbs too much (-18 seconds for 10 wheel revolutions)	<ul style="list-style-type: none">• Count Wheel Revolutions, flow may need to be adjusted via AD Valve/Skimtrol plate.• Verify correct hose float positioning on the leader hose.

Zodiac Australia - Express Warranty and Guarantees

Express Warranty

Zodiac Group Australia Pty Ltd (**Zodiac Australia**) warrants that the Zodiac MX6/MX8 will be free from defects in materials and workmanship for the period of two (2) years from date of purchase. The Zodiac hose is warranted for two (2) years against manufacturing defects and ultraviolet breakdown.

Conditions

- 1 This express warranty only applies if the Product has been purchased from a dealer authorised by Zodiac Australia to supply it (**Authorised Dealer**).

Purchase from an Authorised Dealer ensures that the product is a genuine Zodiac product, that it is the version designed for Asia Pacific conditions, and that the Purchaser has access to appropriate technical knowledge and advice.

- 2 Zodiac Australia's liability under this express warranty is limited, at its option, to the repair or replacement of the Product or the payment of the cost of having the Product repaired or replaced.
- 3 This express warranty does not apply in the following circumstances:
 - (a) if the Product has not been installed in accordance with Zodiac's installation instructions;
 - (b) if the Product has been modified other than as authorised by Zodiac Australia or if a component part has been replaced by a part that is not a genuine Zodiac product;
 - (c) if a defect results from use of the Product outside recommended operating conditions; or
 - (d) if a defect results from damage (including damage to any internal electronics) caused by a power surge or lightning strike.

Zodiac chlorinators are designed and tested in accordance with International Standard EN 61000-6-1 immunity measurements. They are designed to tolerate minor fluctuations (2000 volts) in power supply that can be reasonably expected to occur in the energy grid. They will not tolerate power surges outside these limits nor will they withstand lightning strikes.

- 4 Without limiting 3 above, products sold by Zodiac Australia are designed for use with swimming pool water balanced in accordance with Australian Standard AS3633-1989 with a pH range of 7.0 - 7.8. Maximum chlorine readings should not exceed 4ppm. Where pool water is not maintained within these parameters, Zodiac Australia will not be responsible under this express warranty for any resulting damage, including damage caused by corrosion, scaling or stress loading.
- 5 Replacement parts supplied under this express warranty are warranted to be free from defects in materials and workmanship for the remainder of the warranty period or for 12 months from the supply of the replacement, whichever is longer.
- 6 Warranty claims relating to replacement of the electrodes for LM series, C series, Duo Clear and D series chlorinators are subject to the following pro-rata pricing procedure. The Purchaser must pay for the replacement electrode a proportion of the cost equal to that proportion of the warranty period during which the original electrode functioned effectively. The warranty period for the replacement electrode is the remainder of the warranty period for the original electrode or 12 months from the supply of the replacement, whichever is longer. The Purchaser must pay full cost for any replacement electrodes after the first replacement.

Product warranty registration

- 7 Purchasers should register their Products as soon as conveniently possible after purchase by completing a Product Warranty Registration Form and posting it to Zodiac Australia at the address shown on the Form or by registering online at www.zodiac.com.au.
- 8 Product registration must occur, and proof of purchase must be received by Zodiac Australia, prior to any warranty work being approved. Where applicable, a serial number, installation date and name of installer is required as part of the registration process.

How to make a warranty claim

- 9 The Purchaser must telephone or email Zodiac Australia Customer Service and obtain a warranty ID number for the warranty claim.

Contact details are:

Zodiac Group Australia Pty Ltd

219 Woodpark Road
Smithfield NSW 2164

Customer Service

Telephone: 1800 688 552

Email address: apac.aftersales@zmp.zodiac.com

- 10 Zodiac Australia reserves the right to determine, in relation to each warranty claim, whether the Product should be returned to the Authorised Dealer at the address where the Purchaser purchased the Product or whether warranty service will be provided in the field, repaired at a Zodiac workshop or at the premises of an authorized Zodiac warranty agent.
- 11 If it is necessary for the Purchaser to incur freight charges in making a valid claim under this warranty, Zodiac Australia will reimburse the Purchaser for charges reasonably incurred upon proof of the charges.

Additional guarantees, rights and remedies

Australian Purchasers - Guarantees under the Australian Consumer Law

- 12 The benefits of this express warranty are in addition to other guarantees, rights and remedies Australian consumers have under the Australian Consumer Law.
- 13 Zodiac Australia products come with guarantees that cannot be excluded under the Australian Consumer Law. You are entitled to a replacement or refund for a major failure and for compensation for any other reasonably foreseeable loss or damage. You are also entitled to have the goods repaired or replaced if the goods fail to be of acceptable quality and the failure does not amount to a major failure.

Purchasers in other Countries

- 14 The laws and regulations of other countries may confer on Purchasers in those countries additional rights and remedies. To the extent that they cannot be excluded or modified, Purchasers have the benefits of those rights and remedies in addition to the benefits of this express warranty. To the full extent that it is permissible to do so, those additional rights and remedies are excluded or modified so as to be consistent with Zodiac Australia's express warranty.

INCONSISTENCY WITH WARRANTY STATEMENTS IN PRODUCT MANUALS OR OTHER DOCUMENTS ACCOMPANYING PRODUCTS

If any warranty statements in a Zodiac Australia product manual or other document are inconsistent with the above Express Warranty and Guarantees, the above overrides and replaces the inconsistent statements.



Zodiac is a registered trademark of Zodiac Group Australia Pty Ltd
ABN 87 002 641 965
219 Woodpark Rd, Smithfield, NSW 2164 Australia
Tel: 1800 688 552 www.zodiac.com.au

© Copyright Zodiac Australia Ltd 2013